

# Agilent E1430A 10 MSample/sec ADC, with Filtering and Memory

## Data Sheet

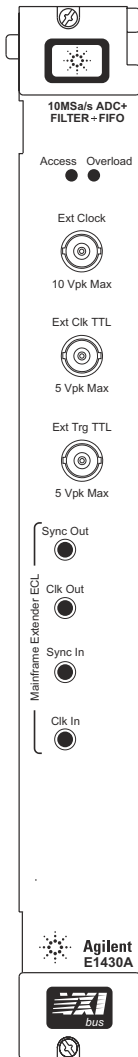

- **18-bit (110 dBFS) spur-free dynamic range**
- **Alias protection**
- **Tunable digital filtering**
- **8 Mbyte FIFO memory**
- **Up to 25 MByte/sec data transfer rate**
- **Internal or external clock**

The Agilent E1430A is more than a digitizer, it is a complete A/D module. Included with its low distortion, low noise, analog-to-digital converter is flexible input signal conditioning, alias protection, tunable digital filtering, a deep FIFO memory and a choice of high-speed interfaces.

### A remarkable A/D

Whether you analyze spectrums or capture transients, digitize IFs or record waveforms, at audio frequencies or baseband, the quality of your measurement starts with the quality of your analog-to-digital conversion. The digitizer in the E1430A uses a combination of dithering and an extraordinary on-the-fly distortion correction technique to produce up to 18 bits (110 dBFS) of distortion-free, spur-free, dynamic range. Low distortion digitizing means higher quality data—data that will reveal even more about the signal when averaged, filtered, or FFT'd.

The E1430A also has low noise. Low noise means better resolution on single-shot events and less processing to resolve the signal on

repetitive events. For the E1430A the noise density is as good as -136 dBFS/Hz. The sensitivity on the lowest input range is -160 dBm/Hz. The noise figure is 14 dB.

### Alias protection

Use the E1430A for spectrum analysis. Its built-in 4 MHz anti-alias filter is ideal for the Nyquist (2X highest frequency of interest) sampling common to that analysis. Alias filtering also limits the noise bandwidth of the input giving lower noise time-domain data as well. And, if you need the fastest rise times possible you can switch the filter out.

### Digital filtering

Sometimes you must narrow in on a signal to exclude unwanted signals or noise. The E1430A features multiple digital filters, with decimation, and a digital LO.

Filter bandwidths range from 4 MHz to 0.24 Hz, in octave steps. After the data is filtered, it is decimated, halving the effective sample rate while maintaining alias-protected Nyquist sampling. This means you get the best of both worlds, digital filtering to exclude unwanted signals, and alias-protected Nyquist sampling, the most data-efficient form of digitizing.

Tune the digital LO to center any of the digital filters on your signal of interest to maximize rejection of unwanted signals. Tune the center



**Agilent Technologies**

Innovating the HP Way

frequency of the filters anywhere in the 4 MHz input range of the module with 10 mHz resolution. Both the I and Q data is output from the filters and is available for processing by the user.

### Sample rate control

A built-in temperature compensated 10 MHz crystal oscillator provides precise sample timing. An optional 10.24 MHz clock (opt AYD) is available for applications requiring the sample rate to be an exact power of 2.

Use the digital filter/decimation capability to reduce the sample rate. This feature reduces the effective sample rate in factor-of-2 steps from 5.0 MHz to 0.47 Hz.

If finer control of the sampling rate is needed an external clock input is available to accept an external sampling clock. And, multiple E1430A's can be connected to sample synchronously.

### Signal conditioning for flexibility

Signal conditioning for flexible AC/DC coupling and 11 attenuation/gain ranges protect the digitizer, letting you digitize a wide range of signal amplitudes.

### Memory for signal capture

A high-speed, 8 Mbyte FIFO memory can be used to capture signals. Use the FIFO feature to store new data while old data is being read out, ensuring gap free data.

### Local Bus for highest speed data transfer

Transfer data off the module over VXI's VME bus or use the high-speed Local Bus. Over the Local Bus the E1430A can transfer blocks of data out at rates up to 40 MBytes/sec.

### Programming

Program the E1430A from VEE and ITG using the preprogrammed drivers that come with VEE. Or, for

the highest speed control and data transfers, program the E1430A's registers directly. A library of C functions is provided to simplify user program development. Filter correction functions are included as well. Source code is included to allow user modification, recompilation to a different target computer, and to provide examples of register programming.

### Summary

When high-resolution, low-distortion, robust data is the key, when signal conditioning, filtering, on board memory and fast data transfers are a must, the E1430A is the answer to your digitizing needs.

**Agilent E1430A  
Block Diagram**

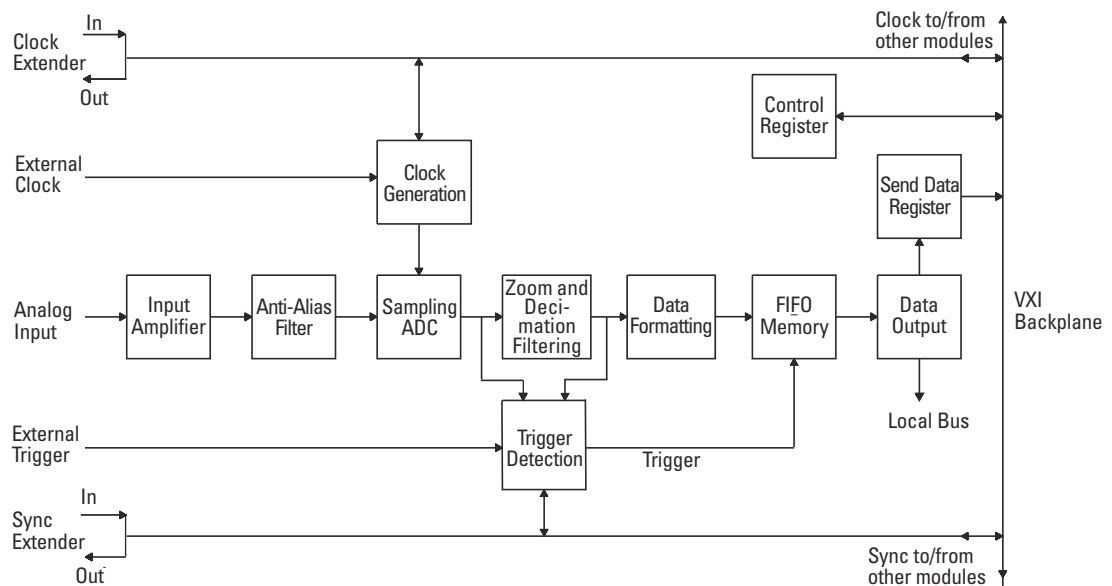

## Specifications

Specifications describe warranted performance over the temperature range of 0° C to 55° C (except where noted) and include a 30-minute warm-up from ambient conditions and automatic calibrations enabled unless otherwise noted. Supplemental characteristics, identified as “typical” or “characteristic,” provide useful information by giving non-warranted performance parameters. Typical performance is applicable over ±5° C from the temperature during the most recent measurement calibration and is not warranted.

<b>Analog Input</b>													
<b>Input Modes</b>	DC coupled, AC coupled, grounded; Single-ended, differential												
<b>Input Ranges</b>													
<b>Input voltage ranges</b> (clipping voltages):	<table border="0"> <tr> <td>±8 Vpk (28 dBm)</td> <td>±0.125 Vpk (-8 dBm)</td> </tr> <tr> <td>±4 Vpk (22 dBm)</td> <td>±62.5 mVpk (-14 dBm)</td> </tr> <tr> <td>±2 Vpk (16 dBm)</td> <td>±31.25 mVpk (-20 dBm)</td> </tr> <tr> <td>±1 Vpk (10 dBm)</td> <td>±15.625 mVpk (-26 dBm)</td> </tr> <tr> <td>±0.5 Vpk (4 dBm)</td> <td>±7.8125 mVpk (-32 dBm)</td> </tr> <tr> <td>±0.25 Vpk (-2 dBm)</td> <td></td> </tr> </table>	±8 Vpk (28 dBm)	±0.125 Vpk (-8 dBm)	±4 Vpk (22 dBm)	±62.5 mVpk (-14 dBm)	±2 Vpk (16 dBm)	±31.25 mVpk (-20 dBm)	±1 Vpk (10 dBm)	±15.625 mVpk (-26 dBm)	±0.5 Vpk (4 dBm)	±7.8125 mVpk (-32 dBm)	±0.25 Vpk (-2 dBm)	
±8 Vpk (28 dBm)	±0.125 Vpk (-8 dBm)												
±4 Vpk (22 dBm)	±62.5 mVpk (-14 dBm)												
±2 Vpk (16 dBm)	±31.25 mVpk (-20 dBm)												
±1 Vpk (10 dBm)	±15.625 mVpk (-26 dBm)												
±0.5 Vpk (4 dBm)	±7.8125 mVpk (-32 dBm)												
±0.25 Vpk (-2 dBm)													
<b>Maximum input voltage without damage:</b>	8 VRMS for any time interval > 10 ms												
<b>Input Impedance</b>	50Ω ±1% DC; > 40 dB return loss to 4 MHz; DC coupled or grounded modes only												
<b>AC Coupling</b>													
	In AC coupled mode, a 0.2 μF ±10% capacitor is placed in series with the input signal. Maximum DC voltage without damage is ±50V when AC coupling is used.												
<b>Common Mode Characteristics</b>													
<b>Impedance to chassis ground:</b>	47Ω ±10% in parallel with 0.04 μF ±10%, differential input mode; < 0.1Ω, single-ended input mode												
<b>Maximum common mode current</b>	±1 Amp peak; diode clamped to < ±1V peak without damage:												
<b>Common mode response:</b> Note: The common mode source for these characteristics is a sine wave voltage source of Vcom mV applied through a 50W series resistor. The characteristics apply for source frequencies < 4 MHz.	< (-90 + 20 × LOG(Vcom)) dBfs, range ≥ 125 mV < (-80 + 20 × LOG(Vcom)) dBfs, range = 62.5 mV < (-65 + 20 × LOG(Vcom)) dBfs, range ≤ 31.25 mV												
<b>Accuracy</b>													
<b>Resolution</b>													
<b>Raw ADC resolution:</b>	23 bits, two's complement												
<b>After digital zoom and filter operations:</b>	32 bits, full resolution mode; 16 bits, reduced resolution mode												
<b>Amplitude Accuracy</b>													
<b>Absolute voltage measurement accuracy:</b>	±0.03 dB (< 100 kHz, ±1V input range, 25° C, analog alias filter on, digital decimation filters off, DC coupled)												
<b>Range accuracy</b> (relative to ±1V range):	±0.03 dB (for all ranges), < 100 kHz												
<b>Alias filter off mode:</b>	±0.02 dB relative to alias filter on mode, 12 kHz												
<b>Temperature drift:</b>	< 0.001 dB per ° C of deviation from 25 °C												
<b>DC Offset</b>													
<b>Programmable DC offset:</b>													
Resolution:	< 0.05% of input range clipping voltage												
Range (minimum):	±50% of input range clipping voltage, range ≥ 62.5 mV												
<b>Input bias current:</b>	< 64 μA (in parallel with 50Ω input load)												
<b>DC offset voltage vs temperature:</b> (% of clipping voltage)	< ±0.01% /° C for 62.5 mV and higher ranges; < ±0.1% /° C for ranges < 62.5 mV												

---

**Dynamic Range**

Note: If you reset the E1430A, and your application depends on the dynamic range specifications, allow at least 20 seconds after the reset for the ADC correction to settle before beginning your measurement.

**Signal-to-Noise Ratio**

The reference signal is a sine wave with peaks at the clipping voltage of the current range.

**Alias filter on:**

70 dB, range  $\geq 62.5$  mV; 62 dB, range  $\leq 31.25$  mV

**Alias filter off:**

66 dB, range  $\geq 62.5$  mV; 53 dB, range  $\leq 31.25$  mV

**Input Noise Density** (Alias filter on, ADC sample clock  $\geq 10$  MHz)**Range  $\geq 62.5$  mV:**

-136 dBfs/Hz,  $f > 100$  kHz  
-134 dBfs/Hz,  $10$  kHz  $\leq f < 100$  kHz  
-130 dBfs/Hz,  $2$  kHz  $\leq f < 10$  kHz  
( $-97-10 \times \text{LOG}(f)$ ) dBfs/Hz,  $f < 2$  kHz

**Range  $\leq 31.25$  mV:**

-127 dBfs/Hz,  $f \geq 200$  kHz  
-122 dBfs/Hz,  $20$  kHz  $< f < 200$  kHz  
( $-79-10 \times \text{LOG}(f)$ ) dBfs/Hz,  $f < 20$  kHz

**Spurious Signals**

(Between 0 to 4 MHz; terminated with  $50\Omega$  at input connector)

$< -110$  dBfs, alias filter on, DSP clock = ADC clock  
 $< -95$  dBfs, alias filter on, DSP clock  $\neq$  ADC clock  
 $< -70$  dBfs, alias filter off, DSP clock = ADC clock

**Distortion****Harmonic distortion products to 4 MHz**

(Includes aliased distortion components)

for inputs  $< -6$  dBfs

$< -80$  dBc or  $< -110$  dBfs

for inputs  $> -6$  dBfs

$< -75$  dBc or  $< -110$  dBfs

**Intermodulation distortion products to 4 MHz**

(Includes aliased distortion components)

for inputs  $< -9$  dBfs

$< -80$  dBc or  $< -110$  dBfs

for inputs  $> -9$  dBfs

$< -75$  dBc or  $< -110$  dBfs

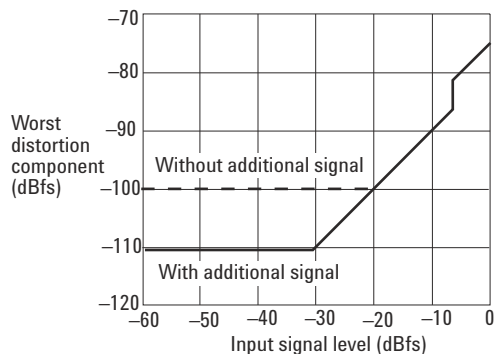
**Distortion vs Input Signal****Phase Noise**

$F_{in} < 4$  Mhz, vibration  $< 0.01G$

**Phase noise density:**

(single sideband power density)

$< -128$  dBc/Hz,  $\Delta f = 100$  Hz

$< -122$  dBc/Hz,  $\Delta f = 50$  Hz

$< -92$  dBc/Hz,  $\Delta f = 5$  Hz

**Discrete sidebands:**

( $5$  Hz  $< \Delta f < 1$  MHz)

$< -110$  dBc, internal clock

$< -80$  dBc, internal clock distributed on backplane

---

**Clock**

Note: The sideband specification for the backplane-distributed clock requires that all modules in the mainframe comply with the VXI 1.4 specification for ECL trigger lines; and that the 10 MHz VXI system clock be turned off. External clock input must be disconnected when not being used for ADC clock.

---

**Clock I/O Connections**

<b>External ADC clock input (ExtClk):</b>	BNC input compatible with TTL, ECL, and > -6 dBm sine waves. AC coupled with input impedance of 1 k $\Omega$ above 10 kHz. $\pm 10V$ absolute maximum input without damage
<b>Clock extender input:</b>	ECL-10K compatible, 50 $\Omega$ termination to -2V, SMB, -7V to + 0.5V without damage
<b>Clock extender output:</b>	ECL-10K compatible, SMB
<b>Sync extender input:</b>	ECL-10K compatible, SMB, -7V to +0.5V without damage
<b>Sync extender output:</b>	ECL-10K compatible, SMB

---

**Clock sources**

<b>ADC clock:</b>	Internal 10 MHz clock (optional 10.24 MHz) External clock, BNC input (the external clock frequency must be > 100 kHz if the DSP clock is the ADC clock, and must be < 4.9 MHz if the DSP clock is internal) ECL clock, SMB input
<b>DSP clock:</b>	Internal 10 MHz clock (optional 10.24 MHz) ADC clock (ADC clock must be > 100 kHz in this mode)

---

**Internal Clock**

<b>Frequency:</b>	10 MHz (optional 10.24 MHz)
<b>Accuracy:</b>	$\pm 70$ Hz, 0 $^{\circ}$ C to 40 $^{\circ}$ C
<b>Jitter (typical):</b>	< 10 ps RMS, 1s interval (see phase noise specification for spectral content of jitter)

---

**Sampling skew (typical)**

<b>Within mainframe:</b>	5 ns
<b>Between mainframes:</b>	20 ns, clock extended via a 1-M coaxial cable

---

**Trigger**

<b>Trigger Sources</b>	External TTL Level LOG(Magnitude) Software (via register write)
<b>Slope</b>	Positive/negative
<b>Threshold</b>	
<b>Level Trigger:</b>	$V_{\text{range}} \times N/128$ , $-128 \leq N \leq 128$ ; hysteresis is $V_{\text{range}}/32$
<b>LOG(Magnitude) Trigger:</b>	$V_{\text{range}}(\text{dBm}) - N \times 0.375$ dBm, $0 \leq N \leq 255$ ; hysteresis is 1.5 dB
<b>External Trigger Input</b>	TTL, BNC, $\pm 10V$ absolute maximum input without damage

---

**Trigger Offset**

<b>Resolution (in output sample periods):</b>	1 sample, 32-bit complex data 2 samples, 16-bit complex or 32-bit real data 4 samples, 16-bit real data
<b>Maximum pre-trigger delay:</b>	1,048,575 × trigger offset resolution
<b>Maximum post-trigger delay:</b>	8,388,607 × trigger offset resolution

---

**Filtering**
**Total Frequency Response**

Total frequency response is: 
$$H(f) = H_{\text{analog}}(f) \times H_{\text{digital}}, N \left( \frac{f - f_0}{f_s} \right)$$

where:

$f$  = input signal frequency

$f_0$  = zoom center frequency (zero in baseband mode)

$f_s$  = ADC sampling frequency (10 MHz with standard internal clock)

$N$  = digital filter bandwidth selector  $N = 0, 1, 2, \dots, 24$

---

**Analog Frequency Response ( $H_{\text{analog}}$ )**
**Analog Flatness (peak to peak)**

Alias filter on: 03 dB,  $f \leq 100$  kHz; 0.25 dB,  $f \leq 2.5$  MHz;  
0.8 dB,  $f \leq 4$  MHz

Alias filter off: 0.25 dB,  $f \leq 4$  MHz; 3 dB nominal,  $f = 20$  MHz

**Stopband rejection:** 100 dB,  $f > 6$  MHz, alias filter on

---

**Analog Frequency Response Function (nominal), with alias filter off**

$$H_{\text{analog}}(f) = \frac{1}{(1 - s/c_0) \prod_{n=1}^2 [(1 - s/c_n)(1 - s/c_n^*)]} \Bigg|_{s = j2\pi f} \quad \begin{array}{l} \mathbf{n} \\ \mathbf{c_n / 2\pi} \\ \hline 0 \\ 1 \\ 2 \end{array} \quad \begin{array}{l} \\ 20 \text{ MHz} \\ 40 + j \times 52 \text{ MHz} \\ 50 + j \times 120 \text{ MHz} \end{array}$$

---

**Analog Frequency Response Function (nominal), with alias filter on**

$$H_{\text{analog}}(f) = \frac{\prod_{n=1}^5 [(1 - s/a_n)(1 - s/a_n^*)]}{(1 - s/b_0) \prod_{n=1}^5 [(1 - s/b_n)(1 - s/b_n^*)]} \Bigg|_{s = j2\pi f}$$

<b>n</b>	<b><math>a_n</math> (Radians/sec)</b>	<b><math>b_n</math> (Radians/sec)</b>
0		$-8.2909964 \times 10^6$
1	$j3.4904432 \times 10^7$	$-7.5372809 \times 10^6 + j9.0528495 \times 10^6$
2	$j3.7024164 \times 10^7$	$-5.7386094 \times 10^6 + j1.6425689 \times 10^7$
3	$j4.2617433 \times 10^7$	$-3.7379055 \times 10^6 + j2.1470763 \times 10^7$
4	$j5.6601087 \times 10^7$	$-2.0233064 \times 10^6 + j2.4424917 \times 10^7$
5	$j1.0424240 \times 10^8$	$-6.3191539 \times 10^5 + j2.5754323 \times 10^7$

---

**Digital Filter Response ( $H_{\text{digital}}$ )**

**Amplitude flatness** ( $1 \leq N \leq 24$ ): + 0/-0.23 dB,  $|f - f_0| < 0.36 \times f_s/2^N$

**Stopband rejection** ( $1 \leq N \leq 24$ ): > 111 dB,  $|f - f_0| < 0.64 \times f_s/2^N$

**Frequency Response Function:**

$$H_{\text{digital}}, N \left( \frac{f - f_0}{f_s} \right) = \begin{cases} 1, & N = 0 \\ \prod_{n=1}^N \left( \frac{z^3 + 2z^2 + 2z + 1}{4z^3 + 2z} \right)^5 \Bigg|_{z = e^{j2\pi(f - f_0)/f_s}}, & N > 0 \end{cases}$$

**Filter characteristics for nominal  
4 MHz analog anti-alias filter**

The following graphs are derived from the analog frequency response function on page 5. They describe the behavior of the 4 MHz analog anti-alias filter located between the ADC and the input connector on the E1430A. All other filters are disabled. Three frequency versus magnitude response curves are provided: Broadband (0 to 40 MHz), Medium band (0 to 6 MHz) and

Narrowband (0 to 4 MHz). Graphs for phase delay, step response and impulse response are also provided. The second graph of the impulse and step responses shows the deviation of the absolute value of the response from its final value in dB. That is, the step response will settle to within 0.1% (-60 db) of its final value in 6.4  $\mu$ sec.

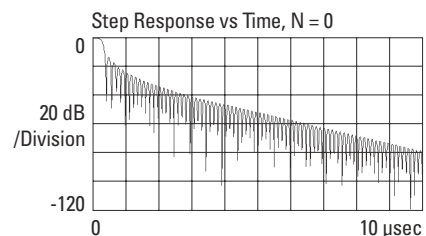
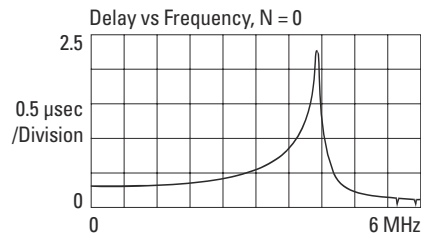
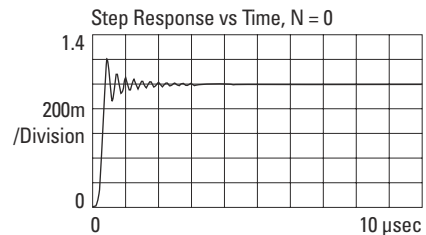
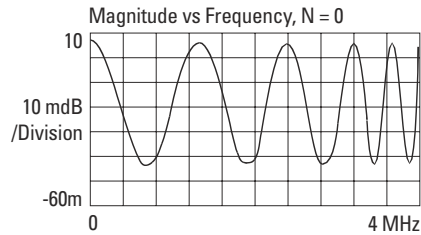
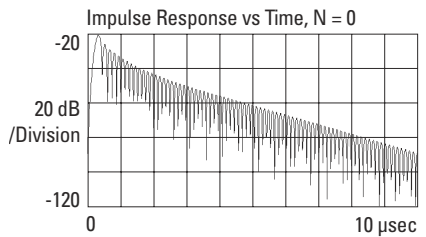
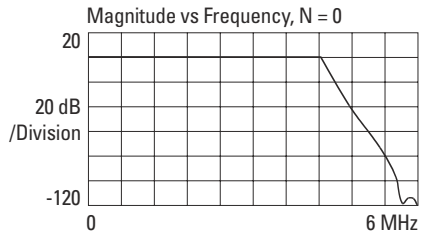
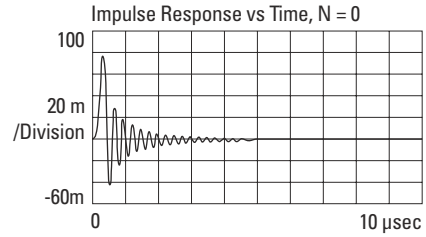
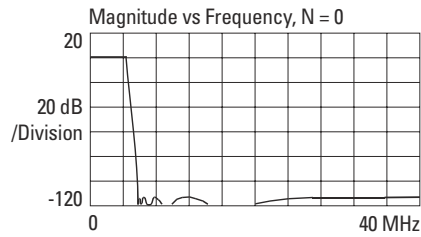

**Filter characteristics for 500 kHz digital filter and analog anti-alias filter**

The following graphs are derived from the frequency response functions on page 5. These graphs show the combined response of the 4 MHz analog anti-alias filter that precedes the ADC and the 500 kHz digital filter that follows the ADC. The responses are dominated by the 500 kHz filter. The shape of the responses is typical of the E1430A digital filters and can be used to estimate the behavior of the < 500 kHz digital filters. Three frequency versus magnitude-response curves are provided: Broadband

(0 to 40 MHz), Medium band (0 to 800 kHz) and Narrowband (0 to 500 kHz). Graphs for phase delay, step response and impulse response are also provided. The second graph of the impulse and step response shows the deviation of the absolute value of the response from its final value in dB. That is, the step response will settle within 0.1% (-60 dB) of its final value in 16  $\mu$ sec.

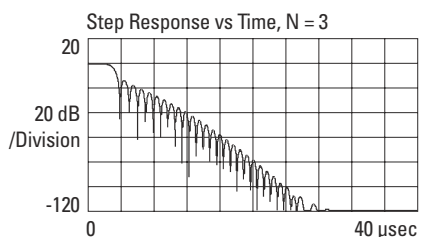
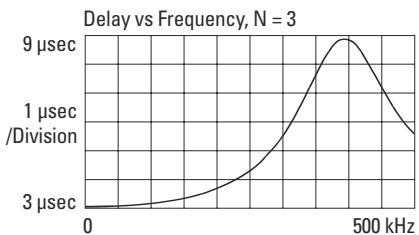
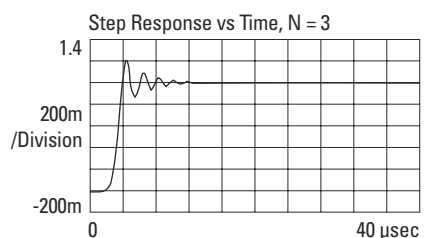
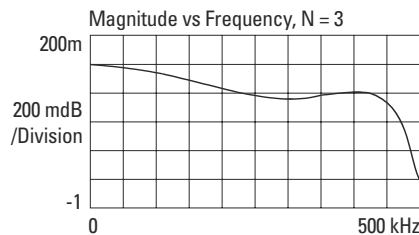
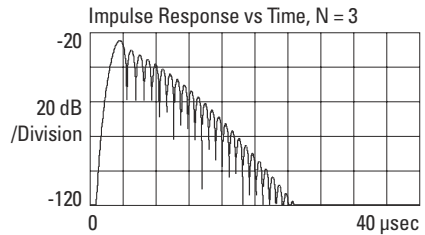
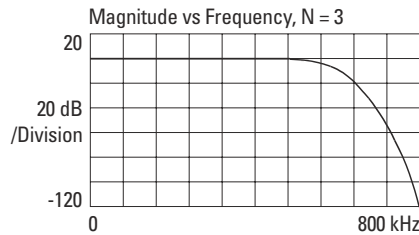
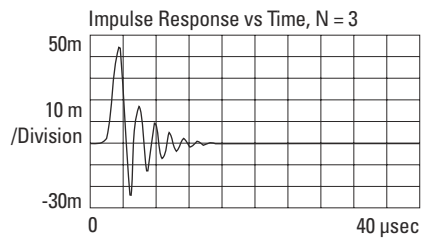
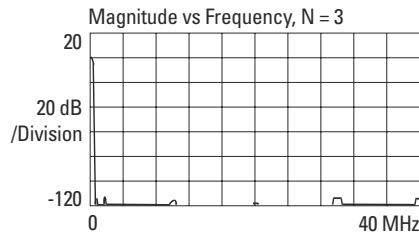



**Filter characteristics with all filtering off  
(based on an approximate model)**

The following graphs are derived from an approximate model of the ADC frequency response when all filters, including the analog anti-alias filter, are switched off. Three frequency versus magnitude response curves are provided: Broadband (0 to 200 MHz), Medium band (0 to 40 MHz) and Narrowband (0 to 4 MHz).

Graphs for phase delay, step response and impulse response are also provided. The second graph of the impulse and step responses shows the deviation of the absolute value of the response from its final value in dB. That is, the step response will settle to within 0.1% (-60 dB) of its final value in 58 nsec.

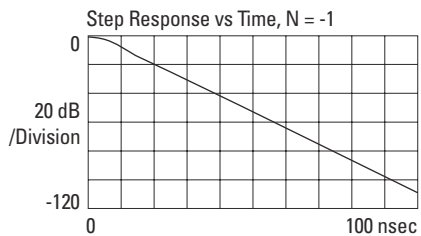
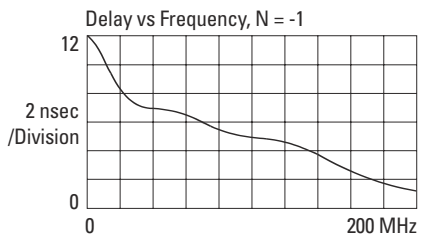
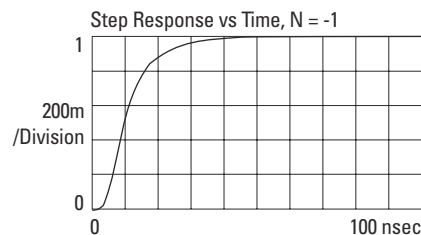
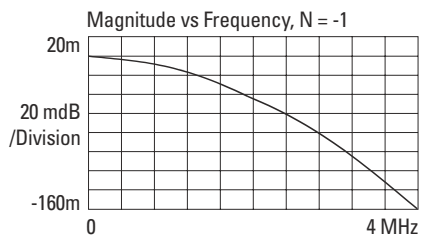
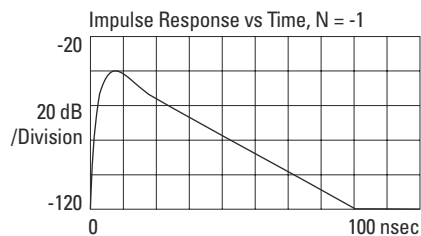
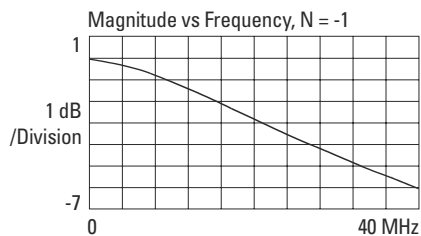
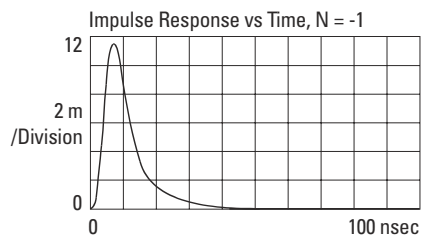
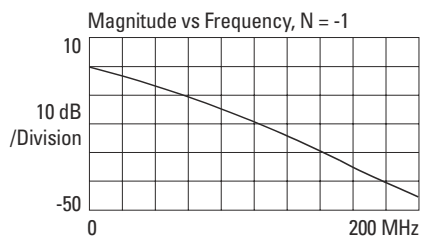

---

**Programming**

All functions are programmable via the VXI register interface.

---

**Center Frequency**

**Resolution:** ADC clock frequency / (1024 × 109)  
**Range:** ± ADC clock frequency / 2

---

**Filtering and Decimation**

**Bandwidths (-15 dB):** ± 0.5 × Fs/2<sup>N</sup>, 1 ≤ N ≤ 24 (See the frequency response section for filter characteristics)  
**Output sample rate:** Fs/2<sup>N</sup> (Nyquist sampled), 2 × Fs/2<sup>N</sup> (2X over-sampled)

---

**Data Output**

**Formats:** real, complex  
**Resolution:** 16 bits, 32 bits  
**Output Ports:** VME data transfers; Local Bus data transfers  
**Transfer rate:** 40 Mbyte/s, local bus, block mode  
20 MByte/s, local bus, continuous mode  
3 MByte/s, VME  
**Block sizes:** 8, 16, 32, ..., 8388608 bytes

---

**Measurement modes:** Block mode (individually triggered blocks); continuous mode

---

**Information Available in Read Registers**

**Manufacturer's Code:** 4095 Decimal (Agilent Technologies)  
**Model Code:** 0454 Decimal (E1430A)  
**Other:** Logical address, status, measurement loop state, data

---

**Status bits:** Data word ready, data block available, armed, measurement done, overload, ADC error

---

**Interrupts:** Two independent priority interrupts initiated by masked status bits.

---

**Memory:** 8 Mb (4 MSamples, 16 bit), FIFO

---

<b>General</b>	
<b>Standards Compliance:</b>	VXI (Rev. 1.4); Register based; A16/D16
<b>DC voltage/current required:</b>	+5V / 4.2A, -5.2V / 4.2A, -2V / 0.3A, +12V / 0.3A, -12V / 0.1A
<b>Dynamic current required:</b>	+5V / 0.5A, -5.2V / 0.2A, -2V / 0.1A, +12V / 0.05A, -12V / 0.02A
<b>Size:</b>	(Single slot, C-size VXI module)
<b>Dimensions:</b>	14 inches deep, 9.2 inches high, 1.2 inches wide (approx. 36 cm deep, 23 cm high, 3 cm wide)
<b>Weight:</b>	3.9 pounds (approx. 1.8 kg)
<b>Temperature Operating:</b>	0° C to 55° C
<b>Temperature Storage:</b>	-20 °C to 65 °C
<b>Humidity, non-condensing</b>	
Operating:	10% to 90% at 40° C
Storage:	10% to 90% at 40° C
<b>Altitude Operating:</b>	4600m (15,000 ft) above 2285m (7500 ft), derate operating temperature by -3.6° C per 1000m (-1.1° C per 1000 ft)
<b>Altitude Storage:</b>	4600m (15,000 ft)
<b>Calibration interval:</b>	1 year
<b>Warm-up time:</b>	1 minute

## **Agilent Technologies' Test and Measurement Support, Services, and Assistance**

Agilent Technologies aims to maximize the value you receive, while minimizing your risk and problems. We strive to ensure that you get the test and measurement capabilities you paid for and obtain the support you need. Our extensive support resources and services can help you choose the right Agilent products for your applications and apply them successfully. Every instrument and system we sell has a global warranty. Support is available for at least five years beyond the production life of the product. Two concepts underlie Agilent's overall support policy: "Our Promise" and "Your Advantage."

### **Our Promise**

Our Promise means your Agilent test and measurement equipment will meet its advertised performance and functionality. When you are choosing new equipment, we will help you with product information, including realistic performance specifications and practical recommendations from experienced test engineers. When you use Agilent equipment, we can verify that it works properly, help with product operation, and provide basic measurement assistance for the use of specified capabilities, at no extra cost upon request. Many self-help tools are available.

### **Your Advantage**

Your Advantage means that Agilent offers a wide range of additional expert test and measurement services, which you can purchase according to your unique technical and business needs. Solve problems efficiently and gain a competitive edge by contracting with us for calibration, extra-cost upgrades, out-of-warranty repairs, and on-site education and training, as well as design, system integration, project management, and other professional engineering services. Experienced Agilent engineers and technicians worldwide can help you maximize your productivity, optimize the return on investment of your Agilent instruments and systems, and obtain dependable measurement accuracy for the life of those products.

### **By internet, phone, or fax, get assistance with all your test & measurement needs**

**Online assistance:**  
[www.agilent.com/find/assist](http://www.agilent.com/find/assist)

#### **Phone or Fax**

**United States:**  
(tel) 1 800 452 4844

**Latin America:**  
(tel) (305) 269 7500  
(fax) (305) 269 7599

**Canada:**  
(tel) 1 877 894 4414  
(fax) (905) 282 6495

**Australia:**  
(tel) 1 800 629 485  
(fax) (61 3) 9210 5947

**Europe:**  
(tel) (31 20) 547 2323  
(fax) (31 20) 547 2390

**New Zealand:**  
(tel) 0 800 738 378  
(fax) 64 4 495 8950

**Japan:**  
(tel) (81) 426 56 7832  
(fax) (81) 426 56 7840

**Asia Pacific:**  
(tel) (852) 3197 7777  
(fax) (852) 2506 9284

Product specifications and descriptions in this document subject to change without notice.  
Copyright © 1994, 2000, 2001 Agilent Technologies  
Printed in U.S.A. February 14, 2001  
5962-9496E



**Agilent Technologies**

Innovating the HP Way